

Wall-Mount Enclosures

Type 4 & 4X Premier™ Series with 2-Point or 3-Point Locking

Data Sheet



Application

- Provides housing for electrical controls and instruments
- Suitable for indoor or outdoor use
- Protects against circulating and windblown dust, falling dirt, dripping non-corrosive liquids, rain, splashing water, and hose-directed water

• Designed to house the following:

1. Allen-Bradley† Bulletin 1494V disconnect switches with flange-mounted variable depth operating mechanisms and Bulletin 1494V flange-mounted variable depth operating mechanisms for circuit breakers.
2. Cutler-Hammer† Type C361 flange-mounted variable depth operating mechanisms with disconnect switches and Type C371 flange-mounted variable depth operating mechanisms for circuit breakers. Also Flex Shaft™ handle mechanisms for circuit breakers.
3. General Electric† Type STDA flange handles and variable depth operating mechanisms for disconnect switches and circuit breakers. Also Spectra Flex™ cable operators for circuit breakers.
4. ITE Max-Flex™† flange-mounted variable depth operating handle for disconnect switches and circuit breakers, as well as some fixed depth operators for disconnect switches.
5. Square D† Class 9422 disconnect switches with flange mounted variable depth operating mechanisms and Class 9422 flange-mounted variable depth operating mechanisms or cable mechanisms for circuit breakers.
6. ABB Controls† flange-mounted variable depth operating mechanisms for disconnect switches and circuit breakers.

† Marks are the property of their respective owners.

Standards

- UL 508 listed, Type 4 or 4X, Type 12 and Type 13
- CSA C22.2 No.94 certified, Type 12 and Type 13
- Conforms to NEMA standard for Type 4 and Type 12/13

Finish

- Wash and phosphate undercoat
- ANSI 61 gray polyester powder finish
- Stainless enclosures are offered with a brushed finish in both 304 and 316L stainless steel.

Accessories

- Premier panels
- NEMA panel adapters
- Depth adjustment brackets
- Print pockets
- Mounting foot kits
- EIA/TIA rack mounting angles
- Swing-out panels

Construction

- Enclosure and door are fabricated from code gauge steel (see table)
- Hardware kit (provided) contains grounding hardware, .312-18 flanged hex nuts for panel mounting, and sealing washers for body mounting holes
- Body flange trough design, formed around body opening, diverts liquid contaminants away from door opening
- Reduced width flange design increases enclosure opening
- Ground stud provided in enclosure body
- .312-18 collar studs are provided for mounting optional Premier panels
- Enclosure mounting holes in body provided for direct mounting or optional mounting feet
- Utility bracket provides wire management and accessory mounting
- Padlocking “tool-to-open” handle with 2-point or 3-point door closing hardware installed
- Door is secured to the body with a unique spring-loaded concealed hinge
- Door is easily removed and interchangeable
- Door has a seamless foam-in-place gasket
- Door opens 170° for easy access
- Latching system interlocks with the disconnect handle for added safety

Discount Schedule: C2

Subclass: TCO & TEO

Important Note

Door closing hardware, handle, latching bar, latching bar bracket interlock, hardware and instruction sheet to locate and install disconnects are furnished with enclosure.

Disconnect switch (or circuit breaker), operating handle and operating mechanism are **not** furnished with enclosure, see disconnect ordering information pages 301 - 306

Notes: Cooper B-Line can provide special sizes, finishes and other modifications. Consult the factory for your special requirements.

Disconnect Enclosures

Wall-Mount Enclosures

Type 4 & 4X Premier™ Series with 2-Point or 3-Point Locking Illustration Sheet and Catalog Number

Disconnect Encl.

Enclosure Catalog Number	Door Gauge in.	Body Gauge in.	Enclosure Size Height x Width x Depth A x B x C		Panel Catalog Number	Panel Size H x W		Mounting D x E		J	
			in.	mm		in.	mm	in.	mm	in.	mm
DSC20228					2020P						
DSC20228SS4	14	16	20.00 x 22.00 x 8.00	508 x 559 x 203	2020PSS4	18.00 x 18.00	457 x 457	18.50 x 20.37	470 x 518	5.0	127
DSC20228SS6					--						
DSC24228					2420P						
DSC24228SS4	14	16	24.00 x 22.00 x 8.00	610 x 559 x 203	2420PSS4	22.00 x 18.00	559 x 457	22.50 x 20.37	572 x 518	6.0	153
DSC24228SS6					--						
DSC24268					2424P						
DSC24268SS4	14	16	24.00 x 26.00 x 8.00	610 x 660 x 203	2424PSS4	22.00 x 22.00	559 x 559	22.50 x 24.37	572 x 619	6.0	153
DSC24268SS6					--						
DSC30268					3024P						
DSC30268SS4	14	16	30.00 x 26.00 x 8.00	762 x 660 x 203	3024PSS4	28.00 x 22.00	711 x 559	28.50 x 24.37	724 x 619	6.0	153
DSC30268SS6					--						
DSC36268					3624P						
DSC36268SS4	14	14	32.00 x 26.00 x 8.00	914 x 660 x 203	3624PSS4	34.00 x 22.00	864 x 559	34.50 x 24.37	876 x 619	6.0	153
DSC36268SS6					--						
DSC36328					3630P						
DSC36328SS4	14	14	36.00 x 32.00 x 8.00	914 x 813 x 203	3630PSS4	34.00 x 28.00	864 x 711	34.50 x 30.37	869 x 771	6.0	153
DSC36328SS6					--						
DSC423212					4230P						
DSC423212SS4	14	14	42.00 x 32.00 x 12.00	1067 x 813 x 305	4230PSS4	40.00 x 28.00	1016 x 711	40.50 x 30.37	1029 x 771	21.0	53
DSC423212SS6					--						
DSC423812					4236P						
DSC423812SS4	14	14	42.00 x 38.00 x 12.00	1067 x 965 x 305	4236PSS4	40.00 x 34.00	1016 x 864	40.50 x 36.37	1029 x 924	21.0	53
DSC423812SS6					--						
DSC483812					4836P						
DSC483812SS4	14	14	48.00 x 38.00 x 12.00	1219 x 965 x 305	4836PSS4	46.00 x 34.00	1168 x 864	46.50 x 36.37	1181 x 924	24.0	610
DSC483812SS6					--						
DSC603812					6036P						
DSC603812SS4	14	14	60.00 x 38.00 x 12.00	1524 x 965 x 305	6036PSS4	58.00 x 34.00	1473 x 864	58.50 x 36.37	1486 x 924	30.0	762
DSC603812SS6					--						

Painted Steel - Part Number alone. Stainless Steel 304 - Part Number with SS4. Stainless Steel 316 - Part Number with SS6.

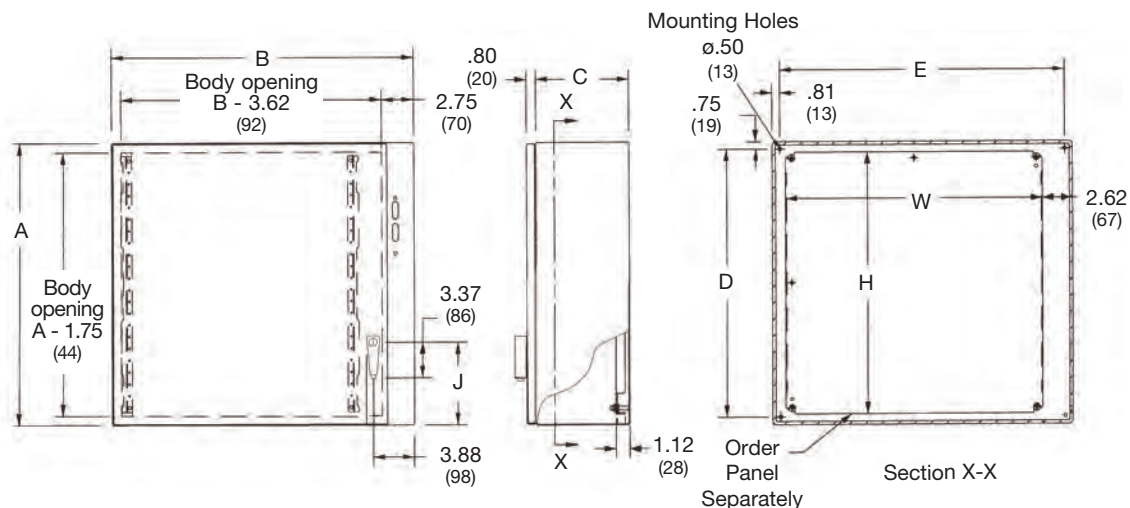

Notes: Dimensions are in inches. Millimeters shown are for reference only. Data subject to change without notice.

Wall-Mount Enclosures Disconnect Ordering Information Allen-Bradley †

1494V Disconnect Mechanism

Allen-Bradley † Mechanism for Switches	Amp	Fuse Clip Rating		Fuse Class	A		B		C (when enclosure depth is:)							
		Amp	Volt		in.	mm	in.	mm	8		10		12		16	
									in.	mm	in.	mm	in.	mm	in.	mm
DS30	30A	(non)	(non)	--	5.75	146	6.37	162	2.87	73	5.25	133	9.75	248	9.75	248
DS30	30A	30A	250V	H,K,R	7.12	181	6.37	162	2.87	73	5.25	133	9.75	248	9.75	248
DS30	30A	30A	600V	H,K,R	9.87	251	6.37	162	2.87	73	5.25	133	9.75	248	9.75	248
DS30	30A	30A	600V	J	7.12	181	6.37	162	2.87	73	5.25	133	9.75	248	9.75	248
DS30	30A	60A	250V	H,K	7.87	200	6.37	162	2.87	73	5.25	133	9.75	248	9.75	248
DS30	30A	60A	600V	H,K	10.37	263	6.37	162	2.87	73	5.25	133	9.75	248	9.75	248
DS30	30A	60A	600V	J	7.25	184	6.37	162	2.87	73	5.25	133	9.75	248	9.75	248
DS60	60A	(non)	(non)	--	5.87	149	6.37	162	2.75	70	5.12	130	9.62	244	9.62	244
DS60	60A	60A	250V	H,K,R	8.00	203	6.37	162	2.75	70	5.12	130	9.62	244	9.62	244
DS60	60A	60A	600V	H,K,R	10.50	267	6.37	162	2.75	70	5.12	130	9.62	244	9.62	244
DS60	60A	60A	600V	J	7.37	187	6.37	162	2.75	70	5.12	130	9.62	244	9.62	244
DS60	60A	30A	600V	H,K,R	10.00	254	6.37	162	2.75	70	5.12	130	9.62	244	9.62	244
DS60	60A	100A	250V	H,K	10.50	267	6.37	162	2.75	70	5.12	130	9.62	244	9.62	244
DS60	60A	100A	600V	H,K	12.50	318	6.37	162	2.75	70	5.12	130	9.62	244	9.62	244
DS60	60A	100A	600V	J	9.25	235	6.37	162	2.75	70	5.12	130	9.62	244	9.62	244
DS100	100A	(non)	(non)	--	8.25	210	7.62	194	*	*	3.62	92	8.12	206	8.12	206
DS100	100A	100A	250V	H,K,R	13.87	352	7.62	194	*	*	3.62	92	8.12	206	8.12	206
DS100	100A	100A	600V	H,K,R	15.87	403	7.62	194	*	*	3.62	92	8.12	206	8.12	206
DS100	100A	100A	600V	J	12.62	321	7.62	194	*	*	3.62	92	8.12	206	8.12	206
DS100	100A	200A	600V	H,K	14.75	375	7.62	194	*	*	3.62	92	8.12	206	8.12	206
DS100	100A	200A	600V	H,K	17.25	438	7.62	194	*	*	3.62	92	8.12	206	8.12	206
DS100	100A	200A	600V	J	13.37	340	7.62	194	*	*	3.62	92	8.12	206	8.12	206
Allen-Bradley † Mechanism for Circuit Breakers	Amp	Circuit Breaker Type		A		B		C (when enclosure depth is:)								
		Manufacturer	Frame(s)	in.	mm	in.	mm	8		10		12		16		
								in.	mm	in.	mm	in.	mm	in.	mm	
M40	150A	General Electric	TED, THED, TEC	6.12	155	4.25	108	4.25	108	6.62	168	11.12	282	11.12	282	
M40	150A	Westinghouse	F (series C)	5.50	140	4.25	108	4.25	108	6.62	168	11.12	282	11.12	282	
M50	250A	Westinghouse	J (series C)	11.00	279	4.50	114	*	*	*	*	10.62	270	10.62	270	
M60	400A	Westinghouse	K (series C)	11.00	279	5.87	149	*	*	*	*	10.50	267	10.50	267	

* Do not install disconnects in this depth enclosure.

The dimensional information provided in this table is derived from information supplied by the manufacturer of the equipment to be installed. Fit and function of all equipment should be checked before and after installation to assure proper and safe operation and compliance with the applicable regulations, codes and standards.

Disconnect Mounting Location

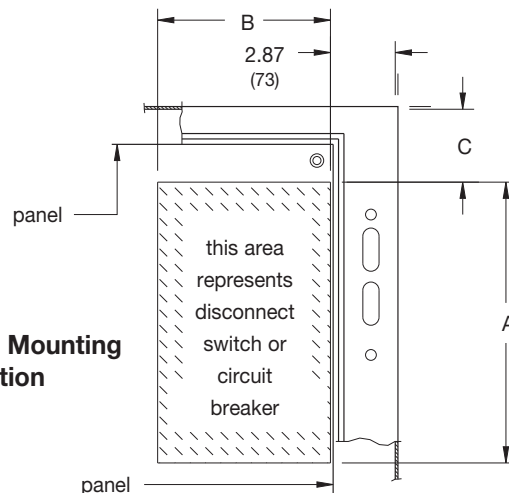

† Marks are the property of their respective owners.

Notes: Dimensions are in inches. Millimeters shown are for reference only. Data subject to change without notice.

Disconnect Enclosures

Wall-Mount Enclosures

Disconnect Ordering Information

Cutler-Hammer †

C361 Disconnect Mechanism

Disconnect Encl.

Cutler-Hammer † Mechanism for Switches	Amp	Fuse Clip Rating		Fuse Class	A		B		C (when enclosure depth is:)							
		Amp	Volt		in.	mm	in.	mm	8		10		12		16	
									in.	mm	in.	mm	in.	mm	in.	mm
NC	30A	(non)	(non)	--	6.00	152	5.75	146	3.50	89	5.75	146	10.25	260	10.25	260
SC21	30A	30A	250V	H,K,R	9.00	229	5.75	146	3.50	89	5.75	146	10.25	260	10.25	260
SC61	30A	30A	600V	H,K,R	9.00	229	5.75	146	3.50	89	5.75	146	10.25	260	10.25	260
SC61	30A	30A	600V	J	9.00	229	5.75	146	3.50	89	5.75	146	10.25	260	10.25	260
SC61	30A	60A	250V	H,K,R	9.50	241	5.75	146	3.50	89	5.75	146	10.25	260	10.25	260
ND	60A	(non)	(non)	--	6.00	152	5.75	146	3.50	89	5.75	146	10.25	260	10.25	260
SD22	60A	30A	600V	J	9.00	229	5.75	146	3.50	89	5.75	146	10.25	260	10.25	260
SD22	60A	60A	250V	H,K,R	9.50	241	5.75	146	3.50	89	5.75	146	10.25	260	10.25	260
SD62	60A	60A	600V	H,K,R	9.50	241	5.75	146	3.50	89	5.75	146	10.25	260	10.25	260
SD62	60A	60A	600V	J	9.00	229	5.75	146	3.50	89	5.75	146	10.25	260	10.25	260
NE	100A	(non)	(non)	--	6.00	152	7.12	181	3.00	76	5.37	136	9.87	251	9.87	251
SE263	100A	100A	250V	H,K,R	10.62	270	7.12	181	3.00	76	5.37	136	9.87	251	9.87	251
SE263	100A	100A	600V	H,K,R	10.62	270	7.12	181	3.00	76	5.37	136	9.87	251	9.87	251
SE263	100A	100A	600V	J	9.37	238	7.12	181	3.00	76	5.37	136	9.87	251	9.87	251
NF (2)	200A	(non)	(non)	--	16.75	425	9.75	248	*	*	*	*	8.00	203	8.00	203
SF264 (2)	200A	200A	250V	H,K,R	16.75	425	9.75	248	*	*	*	*	8.00	203	8.00	203
SF264 (2)	200A	200A	600V	H,K,R	16.75	425	9.75	248	*	*	*	*	8.00	203	8.00	203
SF264 (2)	200A	200A	600V	J	16.75	425	9.75	248	*	*	*	*	8.00	203	8.00	203

C371 Disconnect Mechanism

Cutler-Hammer † Mechanism for Circuit Breakers	Amp	Circuit Breaker Type		A		B		C (when enclosure depth is:)							
		Manufacturer	Frame(s)	in.	mm	in.	mm	8		10		12		16	
								in.	mm	in.	mm	in.	mm	in.	mm
C371E (1)	150A	Cutler-Hammer	HMCP,FS,FH	6.50	165	5.25	133	4.43	113	6.81	173	11.43	290	11.43	290
C371F (1)	225A	Cutler-Hammer	HMCP,JS,JH,JL	11.50	292	7.75	197	*	*	6.75	171	11.25	286	11.25	286
C371F (1)	400A	Cutler-Hammer	HMCP,KS,KH	10.50	267	7.75	197	*	*	*	*	10.75	273	10.75	273
C371G (1)	600A	Cutler-Hammer	LS,LH	9.75	248	11.62	295	*	*	*	*	9.25	235	9.25	235
C371E (1)	150A	Westinghouse	F (series C)	6.50	165	5.25	133	4.43	113	6.81	173	11.43	290	11.43	290
C371F (1)	250A	Westinghouse	J (series C)	11.50	292	7.75	197	*	*	6.75	171	11.25	286	11.25	286
C371F (1)	400A	Westinghouse	K (series C)	10.50	267	7.75	197	*	*	*	*	10.75	273	10.75	273
C371G (1)	600A	Westinghouse	LA,LC	10.87	276	11.62	295	*	*	*	*	9.25	235	9.25	235

* Do not install disconnects in this depth enclosure.

(1) Wire bending space "C" does not allow for the maximum size cable in some depth enclosures.

(2) Do not install 200A switch in enclosures less than 30 inches high.

The dimensional information provided in this table is derived from information supplied by the manufacturer of the equipment to be installed. Fit and function of all equipment should be checked before and after installation to assure proper and safe operation and compliance with the applicable regulations, codes and standards.

Disconnect Mounting Location

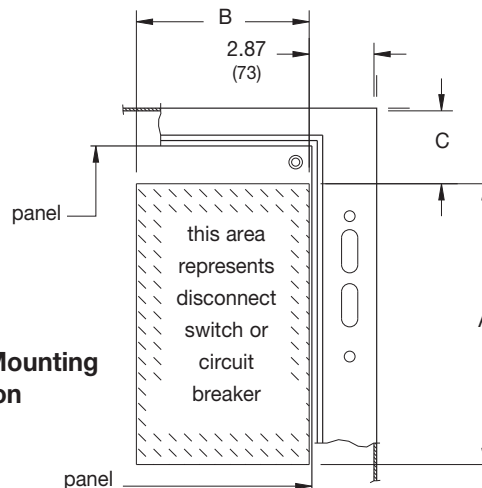

† Marks are the property of their respective owners.

Notes: Dimensions are in inches. Millimeters shown are for reference only. Data subject to change without notice.

Wall-Mount Enclosures Disconnect Ordering Information General Electric †

TDA Disconnect Mechanism

Disconnect Encl.

General Electric † Mechanism for Switches	Amp	Fuse Clip Rating		Fuse Class	A		B		C (when enclosure depth is:)							
		Amp	Volt		in. mm		in. mm		8		10		12		16	
					in.	mm	in.	mm	in.	mm	in.	mm	in.	mm	in.	mm
TDOM1A	30A	(non)	(non)	--	6.31	160	5.00	127	6.18	157	7.62	194	12.12	308	12.12	308
TDOM1A	30A	30A	250V	H,R	6.31	160	5.00	127	6.18	157	7.62	194	12.12	308	12.12	308
TDOM1B	30A	30A	600V	H,R	10.93	278	5.00	127	6.18	157	7.62	194	12.12	308	12.12	308
TDOM1B	30A	30A	250V	H,R	10.93	278	5.00	127	6.18	157	7.62	194	12.12	308	12.12	308
TDOM1B	30A	60A	600V	H,R	10.93	278	5.00	127	6.18	157	7.62	194	12.12	308	12.12	308
TDOM1A	60A	(non)	(non)	--	6.31	160	5.00	127	6.18	157	7.62	194	12.12	308	12.12	308
TDOM1B	60A	60A	250V	H,R	10.93	278	5.00	127	6.18	157	7.62	194	12.12	308	12.12	308
TDOM1B	60A	60A	600V	H,R	10.93	278	5.00	127	6.18	157	7.62	194	12.12	308	12.12	308
TDOM1B	60A	100A	250V	H,R	10.93	278	5.00	127	6.18	157	7.62	194	12.12	308	12.12	308
TDOM1B	60A	100A	600V	H,R	10.93	278	5.00	127	6.18	157	7.62	194	12.12	308	12.12	308
TDOM1A	100A	(non)	(non)	--	6.31	160	5.00	127	6.18	157	7.62	194	12.12	308	12.12	308
TDOM1B	100A	100A	250V	H,R	10.93	278	5.00	127	6.18	157	7.62	194	12.12	308	12.12	308
TDOM1B	100A	100A	600V	H,R	10.93	278	5.00	127	6.18	157	7.62	194	12.12	308	12.12	308
TDOM1B	100A	200A	250V	H,R	10.93	278	5.00	127	6.18	157	7.62	194	12.12	308	12.12	308
TDOM1B	100A	200A	600V	H,R	10.93	278	5.00	127	6.18	157	7.62	194	12.12	308	12.12	308
TDOM2	200A	(non)	(non)	--	9.12	232	8.87	225	*	*	*	*	9.50	241	9.50	241
TDOM2	200A	200A	250V	H,R	17.50	445	8.87	225	*	*	*	*	9.50	241	9.50	241
TDOM2	200A	200A	600V	H,R	17.50	445	8.87	225	*	*	*	*	9.50	241	9.50	241

General Electric † Mechanism for Circuit Breakers	Amp	Circuit Breaker Type	A		B		C (when enclosure depth is:)							
			in. mm		in. mm		8		10		12		16	
			in.	mm	in.	mm	in.	mm	in.	mm	in.	mm	in.	mm
TDOM1A	150A	TEB,TEC,TED,THED	6.43	163	5.00	127	6.06	154	7.50	191	12.06	306	12.06	306
TDOM1B	150A	TBI,TEC,TECL	11.06	281	5.00	127	6.06	154	7.50	191	12.06	306	12.06	306
TDOM1C	150A	TEL	6.43	163	5.00	127	6.06	154	7.50	191	12.06	306	12.06	306
TDOM1D	150A	THLCI	9.75	248	5.00	127	*	*	5.12	130	9.62	244	9.62	244
TDOM3	225A	TFJ,TFK,THFK,TFL	11.43	290	5.50	127	*	*	6.06	154	10.62	270	10.62	270
TDOM4	400A	TJJ,TJK4,THJK4,TJL4V	10.25	260	9.12	232	*	*	5.12	130	9.68	246	9.68	246
TDOM4	600A	TJK6,THJK6,TJ4V,TJL4V	10.25	260	9.12	232	*	*	5.12	130	9.68	246	9.68	246
TDOM5	400A	TB4,TJH6S	16.25	413	9.12	232	*	*	5.12	130	9.68	246	9.68	246
TDOM6	225A	TLB2,THLC2	14.25	362	9.12	232	*	*	*	*	9.12	232	9.12	232
TDOM6	400A	TLB4,THLC4	15.62	397	9.12	232	*	*	*	*	7.75	197	7.75	197

* Do not install disconnects in this depth enclosure.

The dimensional information provided in this table is derived from information supplied by the manufacturer of the equipment to be installed. Fit and function of all equipment should be checked before and after installation to assure proper and safe operation and compliance with the applicable regulations, codes and standards.

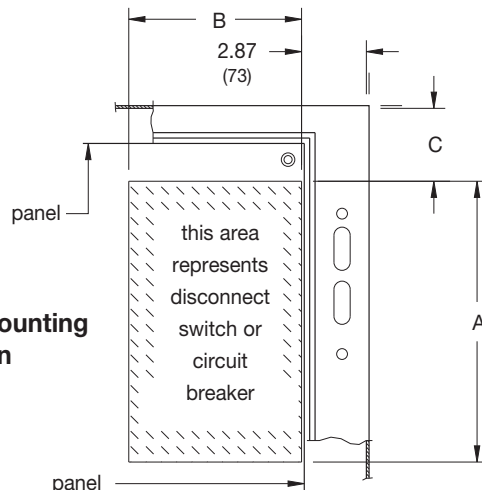

Disconnect Mounting Location

† Marks are the property of their respective owners.

Notes: Dimensions are in inches. Millimeters shown are for reference only. Data subject to change without notice.

Disconnect Enclosures

Wall-Mount Enclosures Disconnect Ordering Information I-T-E Siemens® †

MAX-FLEX Disconnect Mechanism

Disconnect Encl.

Encl. Depth	I-T-E † Mechanism for Circuit Breaker	Cable Length	Amp	Circuit Breaker Frame	A ⁽¹⁾								B ⁽²⁾			
					device		nominal		min		max		device		max	
					in.	mm	in.	mm	in.	mm	in.	mm	in.	mm	in.	mm
8	FHOE036	36	125A	ED,HED,ED6ETI	6.37	162	10.12	257	1.25	32	21.00	533	3.00	76	14.50	368
	FHOE036	36	125A	CED6ETI	8.50	216	13.25	337	4.50	114	24.25	616	3.00	76	14.50	368
	FHOF036	36	250A	FD,HFD,FXD,FXDETI	9.50	241	10.37	263	1.00	25	21.25	540	4.50	114	13.00	330
	FHOF036	36	250A	CFD,CFDETI	14.12	359	15.00	381	3.12	79	21.25	540	4.50	114	13.00	330
	FHOJ036	36	400A	JD,HJD,JXD2,JXD6	11.00	279	10.00	254	1.12	28	20.87	530	7.50	191	14.50	368
	FHOJ036	36	400A	SJD,SHJD,JXD6ETI	11.00	279	10.00	254	1.12	28	20.87	530	7.50	191	14.50	368
	FHOJ036	36	400A	CJD,SCJD,CJD6ETI	17.87	454	16.87	428	6.75	171	26.50	673	7.50	191	14.50	368
	FHOJ036	36	600A	LD,LXD,HLD	11.00	279	10.00	254	1.12	28	20.87	530	7.50	191	14.50	368
	FHOJ036	36	600A	SLD,SHLD,LXD6ETI	11.00	279	10.00	254	1.12	28	20.87	530	7.50	191	14.50	368
FHOJ036	36	600A	CLD,SCLD,CLD6ETI	17.87	454	16.87	428	6.75	171	26.50	673	7.50	191	14.50	368	
10	FHOE036	36	125A	ED,HED,ED6ETI	6.37	162	12.50	318	2.62	67	22.87	581	3.00	76	14.25	362
	FHOE036	36	125A	CED6ETI	8.50	216	16.62	422	5.87	149	26.12	663	3.00	76	14.25	362
	FHOF036	36	250A	FD,HFD,FXD,FXDETI	9.50	241	12.75	324	2.87	73	23.12	587	4.50	114	12.75	324
	FHOF036	36	250A	CFD,CFDETI	14.12	359	17.37	441	5.50	140	28.00	711	4.50	114	12.75	324
	FHOJ036	36	400A	JD,HJD,JXD2,JXD6	11.00	279	12.37	314	2.50	64	22.75	578	7.50	191	14.25	362
	FHOJ036	36	400A	SJD,SHJD,JXD6ETI	11.00	279	12.37	314	2.50	64	22.75	578	7.50	191	14.25	362
	FHOJ036	36	400A	CJD,SCJD,CJD6ETI	17.87	454	19.25	489	9.37	238	29.62	750	7.50	191	14.25	362
	FHOJ036	36	600A	LD,LXD,HLD	11.00	279	12.37	314	2.50	64	22.75	578	7.50	191	14.25	362
	FHOJ036	36	600A	SLD,SHLD,LXD6ETI	11.00	279	12.37	314	2.50	64	22.75	578	7.50	191	14.25	362
FHOJ036	36	600A	CLD,SCLD,CLD6ETI	17.87	454	19.25	489	9.37	238	29.62	750	7.50	191	14.25	362	
12	FHOE036	36	125A	ED,HED,ED6ETI	6.37	162	17.00	432	6.37	162	27.50	699	3.00	76	13.75	349
	FHOE036	36	125A	CED6ETI	8.50	216	19.87	505	9.62	244	30.37	771	3.00	76	13.75	349
	FHOF036	36	250A	FD,HFD,FXD,FXDETI	9.50	241	17.25	438	6.62	168	27.37	695	4.50	114	12.25	311
	FHOF036	36	250A	CFD,CFDETI	14.12	359	21.87	555	11.37	289	32.12	816	4.50	114	12.25	311
	FHOJ036	36	400A	JD,HJD,JXD2,JXD6	11.00	279	16.87	428	6.25	159	26.87	682	7.50	191	13.75	349
	FHOJ036	36	400A	SJD,SHJD,JXD6ETI	11.00	279	16.87	428	6.25	159	26.87	682	7.50	191	13.75	349
	FHOJ036	36	400A	CJD,SCJD,CJD6ETI	17.87	454	23.75	603	13.12	333	33.87	860	7.50	191	13.75	349
	FHOJ036	36	600A	LD,LXD,HLD	11.00	279	16.87	428	6.25	159	26.87	682	7.50	191	13.75	349
	FHOJ036	36	600A	SLD,SHLD,LXD6ETI	11.00	279	16.87	428	6.25	159	26.87	682	7.50	191	13.75	349
FHOJ036	36	600A	CLD,SCLD,CLD6ETI	17.87	454	23.75	603	13.12	333	33.87	860	7.50	191	13.75	349	
16	FHOE036	36	125A	ED,HED,ED6ETI	6.37	162	17.00	432	7.75	197	26.50	673	3.00	76	11.50	292
	FHOE036	36	125A	CED6ETI	8.50	216	19.87	505	11.12	282	29.87	759	3.00	76	11.50	292
	FHOF036	36	250A	FD,HFD,FXD,FXDETI	9.50	241	17.25	438	8.12	206	26.87	682	4.50	114	10.00	254
	FHOF036	36	250A	CFD,CFDETI	14.12	359	21.87	555	13.00	330	31.62	803	4.50	114	10.00	254
	FHOJ036	36	400A	JD,HJD,JXD2,JXD6	11.00	279	16.87	428	7.62	194	26.37	670	7.50	191	11.50	292
	FHOJ036	36	400A	SJD,SHJD,JXD6ETI	11.00	279	16.87	428	7.62	194	26.37	670	7.50	191	11.50	292
	FHOJ036	36	400A	CJD,SCJD,CJD6ETI	17.87	454	23.75	603	14.62	371	33.37	848	7.50	191	11.50	292
	FHOJ036	36	600A	LD,LXD,HLD	11.00	279	16.87	428	7.62	194	26.37	670	7.50	191	11.50	292
	FHOJ036	36	600A	SLD,SHLD,LXD6ETI	11.00	279	16.87	428	7.62	194	26.37	670	7.50	191	11.50	292
FHOJ036	36	600A	CLD,SCLD,CLD6ETI	17.87	454	23.75	603	14.62	371	33.37	848	7.50	191	11.50	292	

- (1) Flexible operating cable allows disconnect to be mounted within minimum and maximum of "A" dimension when "B" is min. (2.87).
 (2) Flexible operating cable allows disconnect to be mounted within minimum, (2.87) and maximum of "B" dimension when "A" is nominal.

The dimensional information provided in this table is derived from information supplied by the manufacturer of the equipment to be installed. Fit and function of all equipment should be checked before and after installation to assure proper and safe operation and compliance with the applicable regulations, codes and standards.

† Marks are the property of their respective owners.

Notes: Dimensions are in inches. Millimeters shown are for reference only.
 Data subject to change without notice.

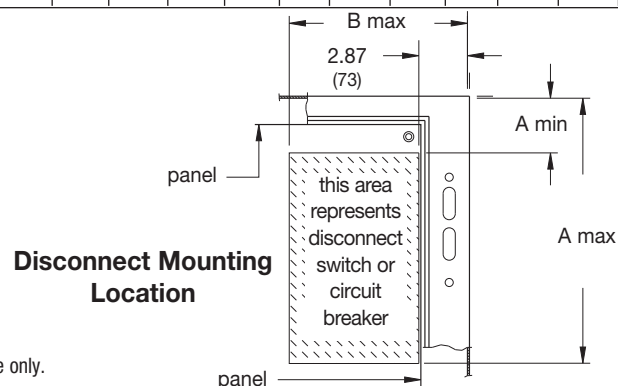

Wall-Mount Enclosures Disconnect Ordering Information Square D® †

9422 Disconnect Mechanism

Disconnect Encl.

Square D † Mechanism for Switches	Amp	Fuse Clip Rating		Fuse Class	A		B		C (when enclosure depth is:)							
		Amp	Volt		in.		mm		8		10		12		16	
					in.	mm	in.	mm	in.	mm	in.	mm	in.	mm	in.	mm
RC-1	30A	(non)	(non)	--	3.37	86	6.87	174	4.62	117	7.00	178	11.50	292	11.50	292
RC-2	30A	30A	250V	H,K,R	5.12	130	6.87	174	4.62	117	7.00	178	11.50	292	11.50	292
RC-3	30A	30A	600V	H,K,R	8.12	206	6.87	174	4.62	117	7.00	178	11.50	292	11.50	292
RC-3	30A	30A	600V	J	5.12	130	6.87	174	4.62	117	7.00	178	11.50	292	11.50	292
RC-3	30A	60A	250V	H,K,R	6.12	155	6.87	174	4.62	117	7.00	178	11.50	292	11.50	292
TC-1	30A	(non)	(non)	--	7.75	197	5.75	146	3.12	79	5.12	130	10.50	267	10.50	267
TC-2	30A	30A	250V	H,K,R	7.75	197	5.75	146	3.12	79	5.12	130	10.50	267	10.50	267
TC-3	30A	30A	600V	H,K,R	7.75	197	5.75	146	3.12	79	5.12	130	10.50	267	10.50	267
TC-3	30A	30A	600V	J	7.75	197	5.75	146	3.12	79	5.12	130	10.50	267	10.50	267
TC-3	30A	60A	250V	H,K,R	7.75	197	5.75	146	3.12	79	5.12	130	10.50	267	10.50	267
TD-1	60A	(non)	(non)	--	9.50	241	6.37	162	3.62	92	6.00	152	10.50	267	10.50	267
TD-2	60A	30A	600V	H,K,R	9.50	241	6.37	162	3.62	92	6.00	152	10.50	267	10.50	267
TD-2	60A	60A	250V	H,K,R	7.62	194	6.37	162	3.62	92	6.00	152	10.50	267	10.50	267
TD-3	60A	60A	600V	H,K,R	10.12	257	6.37	162	3.62	92	6.00	152	10.50	267	10.50	267
TD-3	60A	60A	600V	J	7.62	194	6.37	162	3.62	92	6.00	152	10.50	267	10.50	267
TE-1	100A	(non)	(non)	--	6.12	155	8.12	206	*	*	5.75	146	10.25	260	10.25	260
TE-2	100A	100A	250V	H,K,R	8.87	225	8.12	206	*	*	5.75	146	10.25	260	10.25	260
TE-2	100A	100A	600V	H,K,R	10.87	276	8.12	206	*	*	5.75	146	10.25	260	10.25	260
TE-2	100A	100A	600V	J	7.62	194	8.12	206	*	*	5.75	146	10.25	260	10.25	260
TE-3	100A	200A	600V	J	15.12	384	8.12	206	*	*	5.75	146	10.25	260	10.25	260
TF-1	200A	(non)	(non)	--	8.25	210	11.37	289	*	*	*	*	8.87	225	8.87	225
TF-2	200A	200A	250V	H,K,R	14.25	362	11.37	289	*	*	*	*	8.87	225	8.87	225
TF-2	200A	200A	600V	H,K,R	16.75	425	11.37	289	*	*	*	*	8.87	225	8.87	225
TF-2	200A	200A	600V	J	12.87	327	11.37	289	*	*	*	*	8.87	225	8.87	225
TF-3	200A	400A	600V	J	17.25	438	11.37	289	*	*	*	*	8.87	225	8.87	225

Square D † Mechanism for Circuit Breakers	Amp	Circuit Breaker Type	A		B		C (when enclosure depth is:)							
			in.		mm		8		10		12		16	
			in.	mm	in.	mm	in.	mm	in.	mm	in.	mm	in.	mm
RN-1	100A	FAL,FHL,FCL	6.12	155	4.25	108	3.75	95	6.12	155	10.62	270	10.62	270
RP-1	250A	KAL,KHL,KCL	7.37	187	4.25	108	*	*	6.87	174	11.37	289	11.37	289
RR-1	400A	LAL,LHL,Q4L	12.25	311	4.50	114	*	*	*	*	7.00	178	7.00	178
RR-2	400A	ILL	11.12	282	5.87	149	*	*	*	*	11.37	289	11.37	289

* Do not install disconnects in this depth enclosure.

The dimensional information provided in this table is derived from information supplied by the manufacturer of the equipment to be installed. Fit and function of all equipment should be checked before and after installation to assure proper and safe operation and compliance with the applicable regulations, codes and standards.

† Marks are the property of their respective owners.

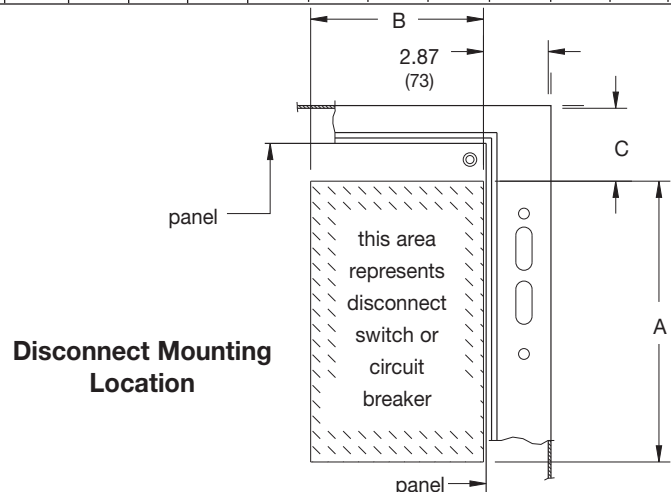

Notes: Dimensions are in inches. Millimeters shown are for reference only. Data subject to change without notice.

Disconnect Enclosures

Wall-Mount Enclosures Disconnect Ordering Information

Disconnect Encl.

ALLEN-BRADLEY †

Standard enclosure designed to accept variable depth type 1494V.

Allen-Bradley† 1494V disconnect switch:

1. Disconnect switch and operating mechanism 1494V.
2. Operating handle 1494V-H1.
3. Trailer fuse block kit, (if required).
4. Fuse clip kit, (if required).
5. Line and load connectors, (if necessary).
6. Door hardware: 2-pt latching mechanism 1494V-L1 or 3-pt latching mechanism 1494-L2.

Allen-Bradley† 1494V circuit breaker:

1. Circuit breaker (General Electric, Westinghouse).
2. Operating mechanism.
3. Operating handle 1494V-H11.
4. Door hardware: 2-pt latching mechanism 1494V-L1 or 3-pt latching mechanism 1494V-L2.

CUTLER-HAMMER †

Standard enclosures designed to accept variable depth types C361 and C371.

Cutler-Hammer† C361 disconnect switch:

1. Disconnect switch and operating mechanism.
2. Operating handle.
3. Door hardware: 2-pt latching mechanism (C361KJ4 or C361KJ6) or 3-pt latching mechanism (C361KJ4 or C361KJ6) and C361KR.

Cutler-Hammer† C371 circuit breaker:

1. Circuit breaker (Cutler-Hammer, Westinghouse)
2. Operating mechanism.
3. Operating handle.
4. Door hardware: 2-pt latching mechanism (C361KJ4 or C361KJ6) or 3-pt latching mechanism (C361KJ4 or C361KJ6) and C361KR.

GENERAL ELECTRIC †

Standard enclosures designed to accept variable depth type TDA.

General Electric† TDA disconnect switch:

1. Disconnect switch (QMR, QMW) and variable depth operating mechanism.
2. Operating handle TDA1.
3. Fuse clip kit or no fuse kit, (if required).
4. Door hardware: 2-pt latching mechanism TDV1 or 3-pt latching mechanism TDV1 and TDV3.

General Electric† TDA circuit breaker:

1. Circuit breaker.
2. Variable depth operating mechanism.
3. Operating handle TDA1.
4. Door hardware: 2-pt latching mechanism TDV1 or 3-pt latching mechanism TDV1 and TDV3.

I-T-E SIEMENS †

Standard enclosures designed to accept MAX-FLEX type FHO.

I-T-E Siemens† MAX-FLEX† circuit breaker:

1. Circuit Breaker.
2. Operating mechanism.
3. Operating handle FHOH.
4. Line and load connectors, (if necessary).
5. Operating cable (standard 36 inch).
6. Door hardware: 2-pt latching mechanism DKR2 or 3-pt latching mechanism DKR3.

SQUARE D †

Standard enclosures designed to accept variable depth type 9422.

Square D† 9422 disconnect switch:

1. Disconnect switch and operating mechanism 9422.
2. Operating handle 9422-A1.
3. Door hardware: 2-pt latching mechanism 9423-M4 or 3-pt latching mechanism (9423-M4 or 9423-M9) and 9423-M3.

Square D† 9422 circuit breaker:

1. Circuit breaker.
2. Operating mechanism.
3. Operating handle 9422-A1.
4. Door hardware: 2-pt latching mechanism 9423-M4 or 3-pt latching mechanism (9423-M4 or 9423-M9) and 9423-M3.

† Marks are the property of their respective owners.

Important Note

When ordering flange-mounted disconnect equipment be sure to include all the necessary components.

1. Latching bar, latching bar bracket interlock and hardware are furnished with the enclosure.
2. Disconnects and related components are available from the manufacturer, see pages 301 - 306.

Notes: Data subject to change without notice.